

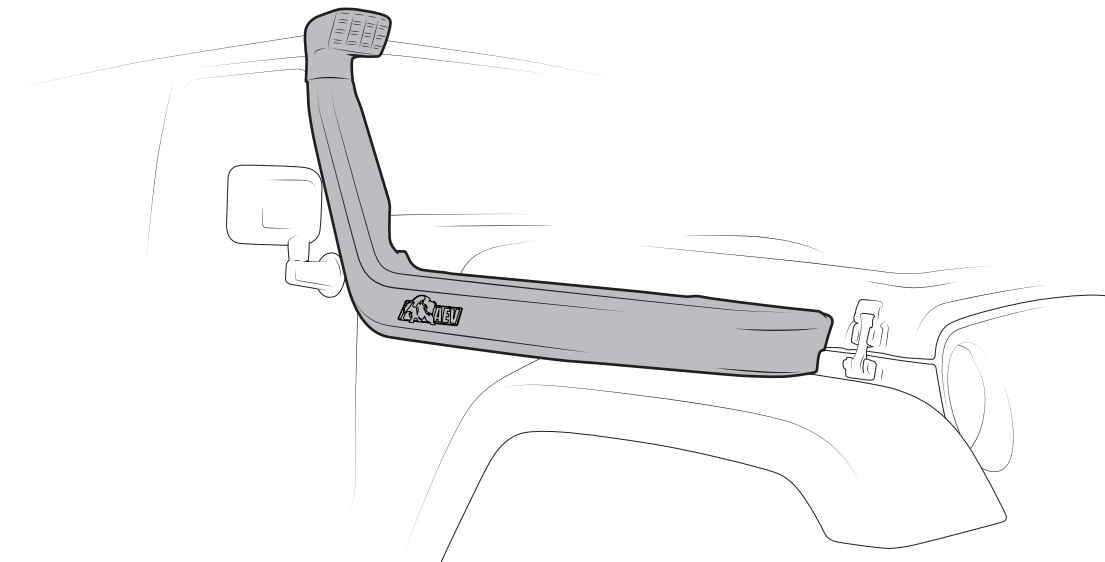

# JK SNORKEL





## PLEASE READ BEFORE YOU START

TO GUARANTEE A QUALITY INSTALLATION, WE RECOMMEND READING THESE INSTRUCTIONS THOROUGHLY BEFORE BEGINNING ANY WORK. THESE INSTRUCTIONS ASSUME A CERTAIN AMOUNT OF MECHANICAL ABILITY AND ARE NOT WRITTEN NOR INTENDED FOR SOMEONE NOT FAMILIAR WITH AUTO REPAIR.

## COUNTERFEIT PRODUCT WARNING

PLEASE BE AWARE THAT THE AEV SNORKEL HAS BEEN COUNTERFEITED. COUNTERFEITERS HAVE BEEN KNOWN TO USE AEV PART NUMBERS AND INSTRUCTION SHEETS. THE PLASTIC USED IS INFERIOR TO MATERIALS USED BY AEV. **AEV DOES NOT OFFER TECHNICAL SUPPORT OR WARRANTY ON THESE COUNTERFEIT PRODUCTS.** WE RECOMMEND ALWAYS PURCHASING AEV PRODUCTS THROUGH AN AUTHORIZED AEV DEALER. TO FIND ONE IN YOUR AREA, VISIT [AEV-CONVERSIONS.COM](http://AEV-CONVERSIONS.COM). IF YOU SUSPECT THAT YOU MAY HAVE PURCHASED A COUNTERFEIT AEV PART, YOU MAY CONTACT AEV FOR VERIFICATION AT **248-926-0256** OR **FAKES@AEV-CONVERSIONS.COM**.

INCLUDED PARTS	QTY	REQUIRED TOOLS
AEV Snorkel	1	Pop-rivet tool
AEV Air Ram	1	Air cut off wheel or body saw
AEV Trim Ring	1	Center punch
Snorkel Bracket A	1	Wax pencil
Snorkel Bracket B	1	Touch up paint
Snorkel Bracket C	1	Masking tape
1/8" SS Rivets for Trim Ring	6	1 3/4" (44.45 mm) hole saw
1/4 - 20 Stainless Steel Bolts	6	1/8" and 5/32" drill bits
Stainless Steel Washers	6	Drill motor
5/32" Rivets for 3.6L Airbox	2	Common hand tools
Hood Cut-out Template	1	Silicone
Anti-Rattle Sleeve	1	



- **BEFORE YOU BEGIN THE INSTALLATION, BE SURE TO CLEAN VEHICLE THOROUGHLY, INCLUDING THE ENGINE COMPARTMENT.**

## **A. INSTALLING WITH AEV HEAT REDUCTION HOOD**

1. If the AEV Heat Reduction Hood is being used, be sure that it is installed at this time. You will need to remove the perforated mesh from the passenger side of the hood.
2. Skip ahead to Step C.

## **B. INSTALLING WITH STOCK JEEP HOOD**

If the stock hood is being used, it is necessary to modify the hood to fit the snorkel. Cut out and place the template (found on the last page of this Installation Guide) onto the right side of the hood. Measure 3/4" (23 mm) back from the hood latch indentation as shown on the template. Mark out the cut line on the exterior of the hood using a wax pencil and then center punch the center of the 1 3/4" (44.45 mm) circle.

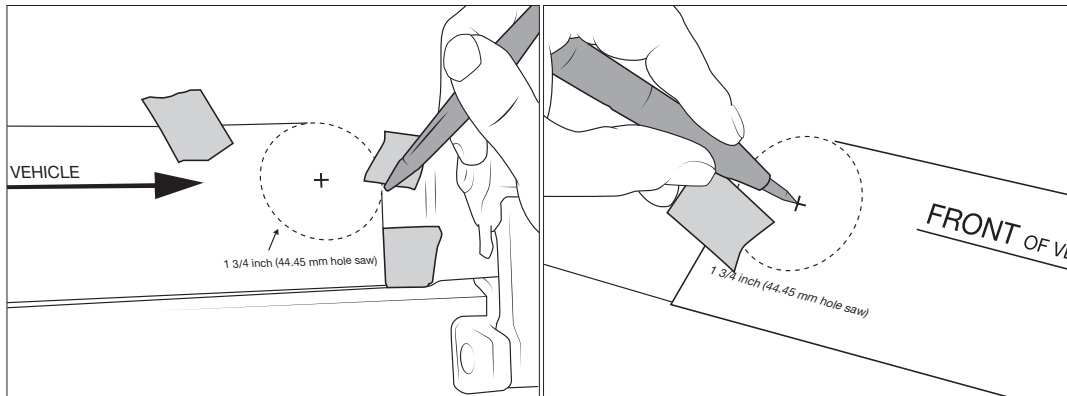

1. Temporarily prop the hood up approximately 4-6" (100-150 mm) in order to cut the hood without damaging the fender or any under hood components. Cover and protect all glass, plastic and painted parts from sparks.
2. Use a pilot drill to drill both layers of the hood first, then use the 1 3/4" (44.45 mm) hole saw to carefully cut through both layers of the hood.
3. Using a cutoff wheel or reciprocating body saw, cut out the rest of the opening.

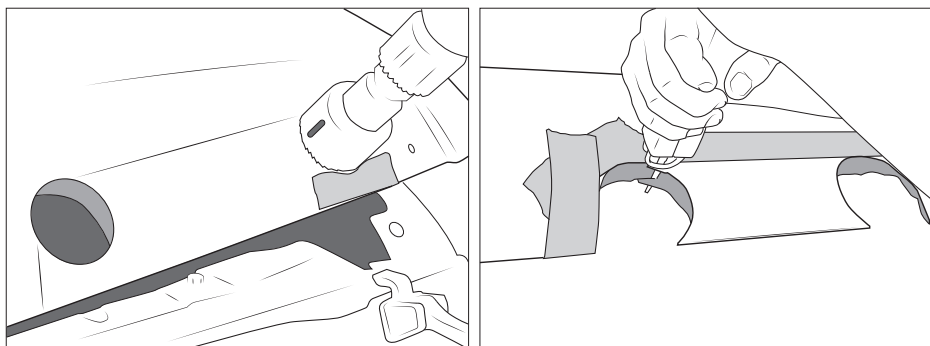



4. Mark the inside of the hood as shown. Draw the cut line approximately 1/4" (6 mm) lower than the bend of the hood as shown. This can easily be done by holding a marker such that your finger can be used as a guide. Finish by marking the rest of the area to be removed.

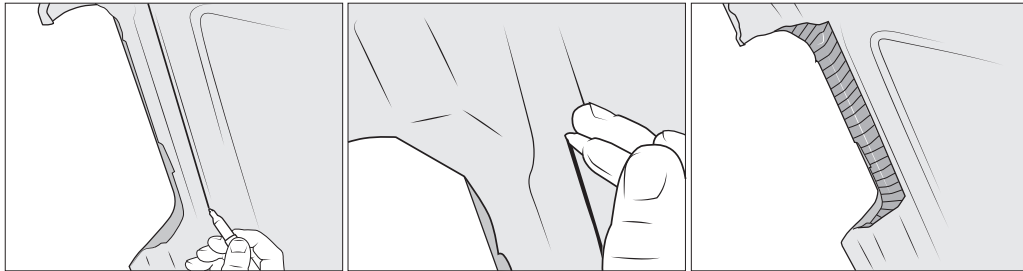

5. Using the cutoff wheel, clearance the hood inner so that it clears the opening when viewed from the side.
6. Use touch up paint or rust inhibitor such as MOPAR #82300508 on all areas affected. On lighter colored vehicles, you may want to "black out" the hood inner so that it is not noticeable. Mask and paint as desired.

## C. REMOVE THE FACTORY AIRBOX

1. Remove airbox top
  - b. 3.6L Gas Models: Remove two bolts attaching engine intake hose to top of radiator. Loosen the clamp on the engine intake hose. Separate the intake hose and crankcase breather hose (gas) from the airbox and remove the top of the airbox from the vehicle.
  - c. 3.8L Gas Models: Loosen the clamp on the engine intake hose. Separate the intake hose and crankcase breather hose (gas) from the airbox and remove the top of the airbox from the vehicle.
  - d. 2.8L Diesel Models: Loosen the clamp on the turbo intake hose and unplug the MAP and IAT sensors. Remove the top of the airbox from the vehicle.
2. Remove the air filter and lower portion of the airbox. The airbox simply pulls vertically out of rubber mounts.



## D. INSTALL THE SNORKEL

1. Install the mounting brackets to the snorkel. Center the mounts in the recessed areas in the snorkel and attach the brackets using the 1/4"-20 bolts and washers. Do not tighten completely at this time – just enough to allow some movement for adjustment (fig 3.1).
2. Remove the fender bolts (fig 3.2) and windshield bolts (fig 3.2) to prepare the vehicle for mounting the snorkel.

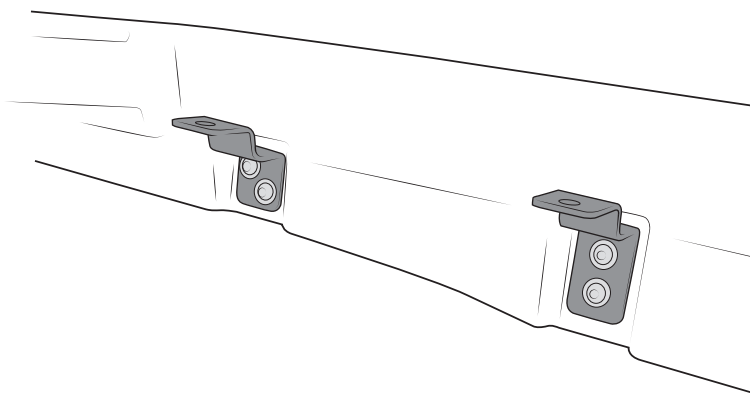

Figure 3.1

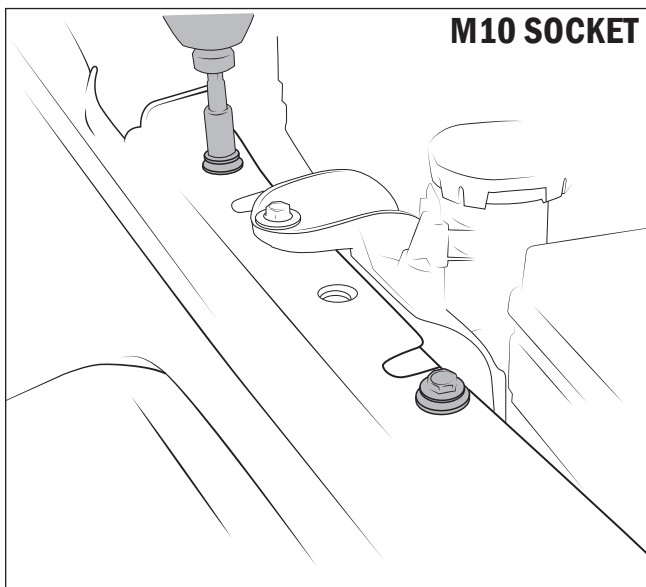
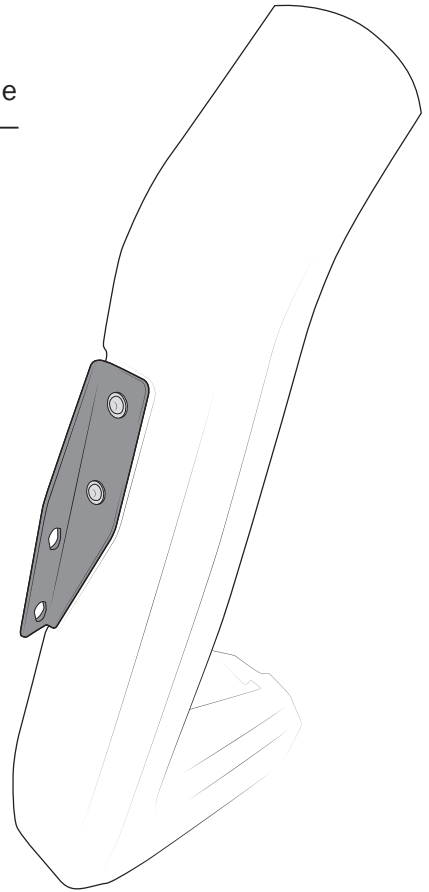

Figure 3.2

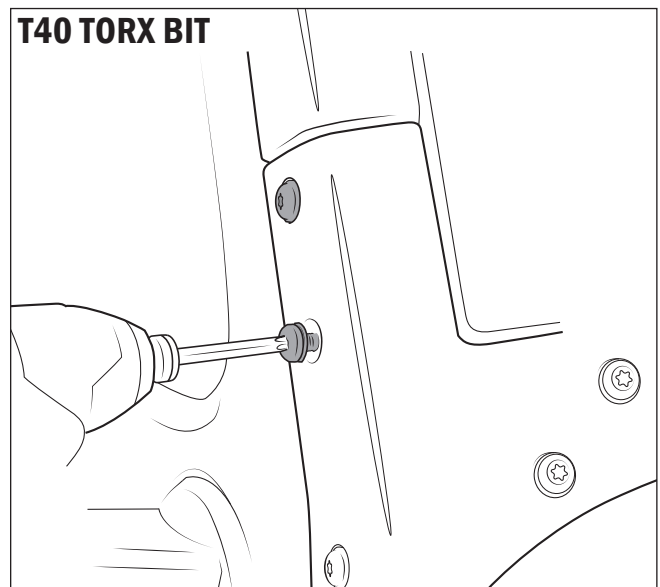

Figure 3.3



3. Remove the short factory “snorkel”.
  - a. 3.6 L Gas Models: you will need to drill out the rivets that attach the factory “snorkel” to the airbox. (Fig. 4.1)
  - b. 3.8 L Gas Models: Squeeze the “snorkel” from the inside of the airbox and remove.
4. 3.8 L Gas Models: Cut off the small locator on the factory airbox (shown in gray Fig. 4.2)

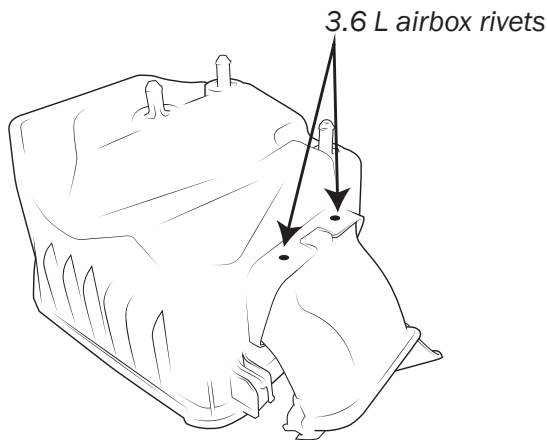

Figure 4.1

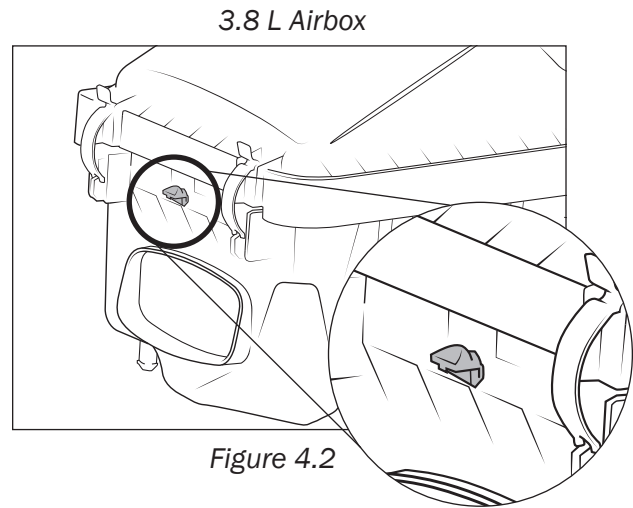
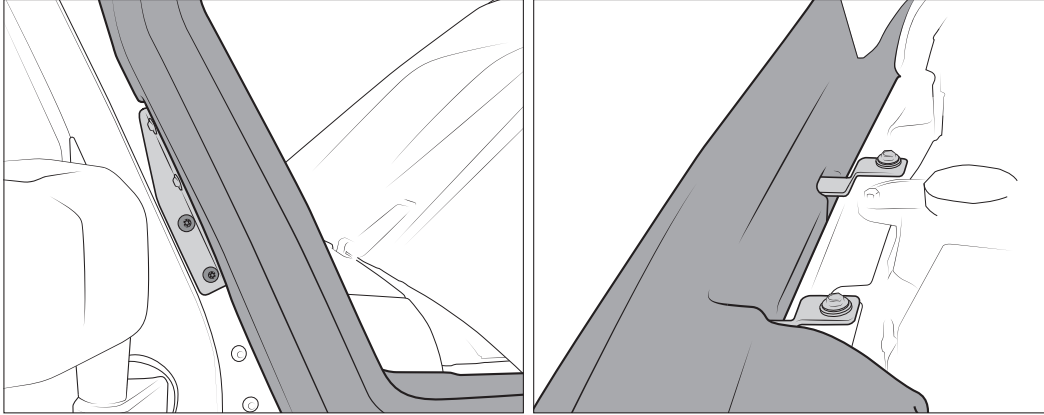

Figure 4.2

5. Install the AEV Snorkel into the factory airbox.
  - a. 3.6 L Gas Models: Drill through the existing airbox rivet holes into the AEV Snorkel with a 5/32” drill bit. Secure with the supplied rivets.
  - b. 3.8 L Gas Models: Push Snorkel end in the airbox opening to snap in.
6. Use Silicone to seal the snorkel to airbox joint. There are several drain holes in the bottom of the factory airbox, for typical usage (dust and occasional water crossings) we recommend leaving these holes open. For extreme water use, using silicone to seal these holes shut is correct, but after all deep water crossings or when the airbox is subjected to prolonged submersion, inspection for water in the airbox is recommended.
7. Install the snorkel/airbox back into the vehicle. Lubricate the rubber airbox isolators to get the airbox to seat properly.



8. Install the fender bolts and windshield bolts temporarily in order to fit the snorkel for adjustment.



9. Test fit the hood to snorkel clearance. The snorkel and hood should have roughly a 1/8" (3mm) gap surrounding the front and top of the snorkel.
10. Adjust the brackets for the best fit and then tighten every bolt and bracket.
11. Install the AEV Trim Ring (optional on AEV Heat Reduction Hoods). Place the AEV Trim Ring on the hood and adjust it so that the visual gap between the hood and the snorkel is even. Mark the location of the holes on the hood and drill to 1/8". Paint the holes with touchup paint and install the AEV Trim Ring using the supplied stainless steel rivets.

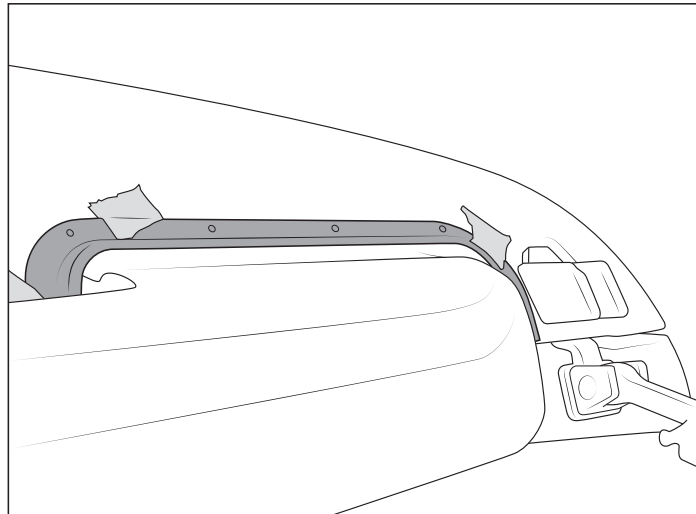



12. Reinstall the filter, top of the airbox and all hoses.
13. Install the AEV Air Ram or optional Pre-Filter (follow instructions included with the pre-filter). Tighten the supplied hose clamp. Adjust the AEV Air Ram or pre-filter so that it sits straight and level when viewed from the front and side of the vehicle.

---

## AEV PRE-FILTER AVAILABLE AT [AEV-CONVERSIONS.COM](http://AEV-CONVERSIONS.COM)



AEV's Pre-Filter Assembly is designed to draw in air, while separating rain and dust from the air charge. It is well suited for dry, desert terrain where this dust is likely. Using the same criteria for military and commercial vehicles worldwide, this rugged Pre-Filter is self-cleaning and will last the lifetime of the snorkel. This Pre-Filter will remove virtually all dust and debris, before it ever has a chance to clog your air filter. With many customers reporting no need to change air filters for over a year, this Pre-Filter will pay for itself.

PN: 40306225

### E. SNORKEL USAGE AND CARE INSTRUCTIONS

This product is intended to provide clean, dry air to the engine but does not necessarily mean the vehicle can exceed the manufacturer's recommended fording depth. There are many considerations to make when increasing fording depth and a snorkel is just one small part. While a snorkel can be a real lifesaver in an occasional accidental deep water crossing, the benefits can most easily be seen in every day dust prevention — especially when equipped with the optional pre-filter.

### F. ANTENNA ANTI-RATTLE DEVICE

The radio antenna may contact the snorkel body. This can result in a rattle from the two parts tapping against each other. In order to cure this issue we have included an anti-rattle sleeve. To install, slide the sleeve over the antenna all the way down to the base.

### COMMENTS OR QUESTIONS?

American Expedition Vehicles

[www.aev-conversions.com](http://www.aev-conversions.com)

email: [tech@aev-conversions.com](mailto:tech@aev-conversions.com)

ph: 248.926.0256

**Be sure to visit our forum at: <http://forum.aev-conversions.com>**



# FRONT OF VEHICLE

1 3/4 in (44.45 mm) hole saw

align flush with outer hem tangent

1 3/4 in (44.45 mm) hole saw

place 23 mm from latch pocket tangent  
(see detail below)

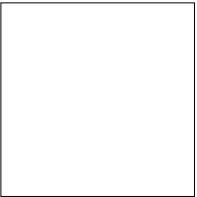

1 inch (25.4 mm) sq.  
Check print scale

