



Installation Instructions

MasterTop Complete Soft Top for 18-Current
Jeep® JLU 4Dr. Wrangler
Item #156016XX



Part List:

Top Deck/Header and Rear Bows assembly-QTY 1
Driver side quarter Window - QTY 1
Passenger side quarter window - QTY 1
Rear window - QTY 1
Center bow assembly- QTY 2
Driver side door surround- Qty 1
Passenger side door surround- QTY 1
Door surround Rubber - Qty 2
Door Surround Screws - Qty 4
Door surround knobs-QTY 8
Tailgate Bar - QTY 1
Tailgate Bar Corner Mounts - QTY 2
Corner Mounts short knobs - QTY 2
Rear bow screws & nuts - Qty 4
Rear bracket screws & nuts - Qty 2
Rear Main bracket screws and nuts - Qty 2
4mm Allen Wrench - QTY 1
Rear Main Bracket Screws M8 - Qty 4
5mm Allen Wrench - Qty 1

Required Tools:

Safety glasses
Socket wrench
10mm socket
Phillips head screw driver

WARNING

Loss of vehicle control involves risk of death or serious injury, particularly to parts of your body not restrained within vehicle. This product is intended for weather protection only and should not be relied upon to contain occupants in the event of an accident or to protect from either ground contact or falling objects. To reduce risk of accident or injury:

- ALWAYS WEAR SEATBELTS
- Always keep head, arms & body parts within vehicle.
- Fully secure or stow the soft top before driving according to instructions. Never try to latch or fold soft top while driving. Do not use if damaged or worn.
- Read and follow all instructions & warnings accompanying this product, in your vehicle owner's manual and Off Road Driving Supplement.

CAUTION

RISK OF EYE INJURY. Safety glasses should be worn at all times while installing or maintaining this product.



Important Safety information

Your MasterTop® Complete Soft Top is intended to increase the utility and enjoyment of your off road capable vehicle. Before installation, please take a moment to review the following safety information and installation instructions. Important safety information is generally preceded by one of three signal words indicating the relative risk of injury.

The signal words mean

WARNING A hazardous situation which, if not avoided, could result in death or serious injury. You **CAN** be **KILLED** or **SERIOUSLY HURT** if you don't follow instructions.

CAUTION A hazardous situation which, if not avoided, could result in minor or moderate injury. You **CAN** be moderately **HURT** and also may suffer property damage if you don't follow instructions.

NOTICE Careful attention is required to this instruction or operation but does generally not relate to personal injury. Damage to your Mastertop® product or other property may result if you don't follow instructions.

Before you begin Installation:

Congratulations on your purchase of the MasterTop Complete Soft Top! This high quality soft top is designed to provide years of protection from whatever nature can throw at you! We have used only the finest materials in creating this soft top but like any product that is exposed to the elements, there is some general maintenance that is required to keep your Top looking like new. Please see page 13 for these important maintenance tips.

Thank you again for your purchase and let's start the installation process!

NOTICE For a smooth fit and ease of installation, this top should be installed at temperatures above 72 degrees. Below this temperature, the fabric may contract an inch or more making it difficult to install. We highly recommend taking the top out of the package and letting it sit inside a warm place or direct sunlight for 1-2 hours before you install the top. When warm, this top will install quickly.

When unpacking, carefully check to make sure all parts are included.

If any part is missing or broken, please call MasterTop customer service at 720-575-5440.

Step 1: Un-packing & Organizing the Door Surrounds:

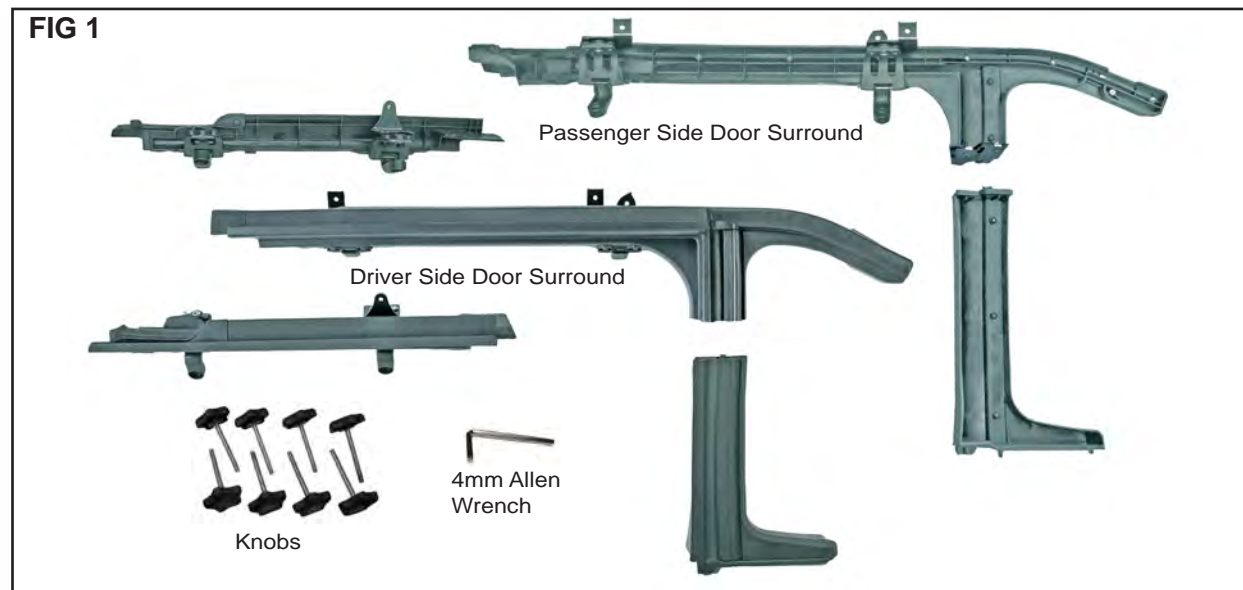

Put on safety glasses. Carefully remove all the contents of the large shipping box onto a table top or onto the grown on top of a soft towel.

Once the components are removed from the shipping box, locate the front and rear door surround components and accessories as shown in FIG1.

Carefully remove the contents of each box organizing them as shown in Fig.1 making sure the passenger side and driver's side components are separated.



Step 2: Rear Over Door Surround Assembly

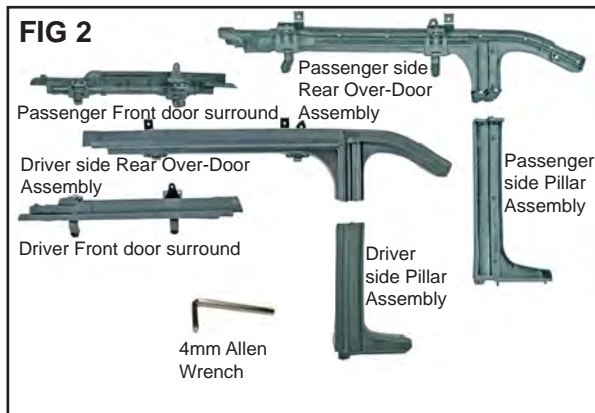

Locate the driver's side rear over door assembly, the driver's side Pillar assembly, the Rubber seal and the 4mm Allen head wrench (Fig 2).

On the driver's side rear over door assembly, there are two screws installed for shipping (Fig 3). Remove these screws and set aside. Place the rubber seal on the driver's side pillar assembly (Fig 3A) Line up the Driver side pillar assembly and the driver side rear over door assembly as shown in fig 4. Insert the screws and tighten using the included 4mm Allen wrench securing the two pieces (fig 5).

Repeat the above assembly on the passenger side rear over door and pillar assemblies.

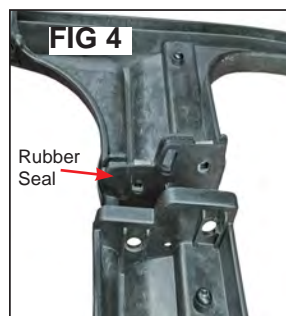

Step 3: Install Rear Door Surrounds to Jeep



Locate the assembled Driver's side rear door surround (Fig 6).

On the bottom of the vertical pillar portion of the assembled door surround are two pins as shown in FIG 7 that will be inserted into the body tub.

Insert this pin into the body tub as shown in FIG's 8 & 9.

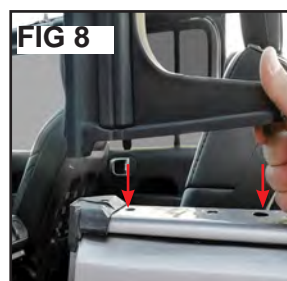

Repeat this procedure on the passenger side rear door surround.



Step 4: Secure Front & Rear Door Surrounds to the Roll Bar



Locate the two sets of screw knobs and the driver's side front and rear door surrounds. There should be 2 sets of four knobs. These knobs go on the front and rear holes of the Brackets previously installed in step 3 on the door surrounds.

Line up the front driver's side door surround bracket holes with the vertical holes in the over door horizontal roll bar. Slip the front two knobs through the brackets holes in the front door surround (FIG10) lining it up with the hole in the top of the surround bracket on top of the front horizontal roll bar. If you use a rolling motion while you push the brackets on it will be easier to install. Repeat on the passenger side of the vehicle (See note below). Loosely tighten each of the knobs securing the front door surround.

Note: if you have difficult lining up the top of the knobs with the upper bracket hole, rotate the bottom of the door surround pin out of the body tub slightly towards you and start the knob. Rotate the pins back into the tub and tighten knob. You can also remove the installed top brackets covering the top hole to get a better view of how the screw lines up. Fig 11a & 11b. Repeat on the passenger side of the vehicle.

Step 5: Secure Front & Rear Door Surrounds to the Roll Bar Continued

Line up the rear end of the front door surround with the front of the rear door surround as shown in fig 12. Make sure the rear door surround seals are on top of the front Door Surrounds as shown in Fig 13. Line up the rear door surround bracket holes with the vertical holes in the rear horizontal roll bar. If you use a rolling motion while you push the brackets on it will be easier to install. Slip the two knobs through the brackets holes in the rear door surround. Loosely tighten the knob securing the front door surround.

Note: if you have difficult lining up the top of the knobs with the upper bracket hole, you can remove the installed top brackets covering the top hole to get a better view of how the screw lines up. Repeat on the passenger side of the vehicle.



Step 6: Installing the Center Bow #1 & #2



Locate the center bow #1 (Fig 14). Each Bow has been labeled to make identification easier. Loosen the screws holding on the top brackets. With the help of a friend, place the Quick release end on the bottom of the bow leg over the second vertical bracket (Fig 15). Pull the quick release knob out and push the bow down mounting the quick release to the bracket. The quick release knob is spring loaded so you should here a “click” when it is secure in the bracket (Fig 16). once the bow is installed, tighten the bow mount bracket on the door surround.



Repeat this bow mounting on the other side of the vehicle and then repeat the above procedure with center bow #2 (FIG 14). Tighten down the door surround knobs on each side of the vehicle securing the Door surrounds and the two bows.



Step 7: Installing the Deck and Front Windshield Header



With the help of a friend you will need to lay the entire top deck assembly onto the vehicle with the topping fabric/vinyl facing up and the front header resting on the windshield (Fig 17). Locate the two rear bow arms attached to the front windshield header (Fig 18).



Step 8: Installing the Deck and Front Windshield Header Continued



The bow arms will install to the front bow mount brackets located on the top of the door surrounds. Loosen the bow mount brackets mounted on the door surround. With the help of a friend, lift each of the bow legs over the bow mount bracket (Fig 19). Once lined up with the bow mount bracket, install the header assembly by pulling out the quick release knob and push over the mount until you hear a "click" (Fig 19). The front header should now easily rest on top of the windshield when folded down. Tighten the Bow mount brackets on the front door surround.

Repeat on the passenger side.

Step 9: Installing the Rear Legs to the Rear Bow



With the front header folded back towards the rear of the vehicle (Fig 20), and the rear bow #3 folded to the front (Fig 21). Locate the #4 rear bow. There is a screw and nut installed for shipping (Fig 22). Remove this screw and nut using a 10mm socket and the included 5mm Allen head tool and set aside.

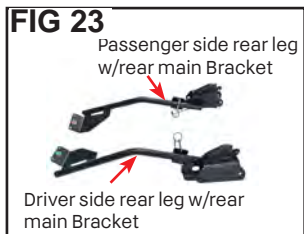

Locate the rear leg with rear main bracket installed for shipping (Fig 23). Line up the driver's side rear leg with main bracket to the rear bow #3 as shown in fig 24.

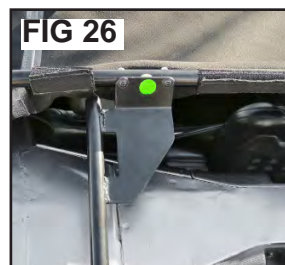

Insert the previously removed screw to the hole and place the nut to the screw and tighten with the included 4mm Allen wrench to secure as shown in fig 25 & 26.

Repeat the above on the other side of the vehicle



Step 10: Installing the Rear Main Bracket to the Vehicle



On the rear sport bar, pull off the plastic bracket that comes with the jeep, there is two metal clips that hold it in place (Fig 27).

Line up the rear main bracket over the holes (Fig 28). Insert the M8 screws and using the included 5mm Allen head tool, tighten the bracket in place (Fig 29).

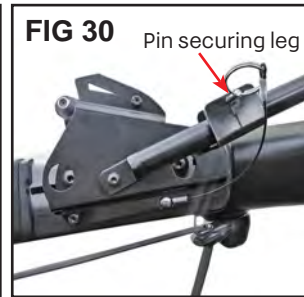
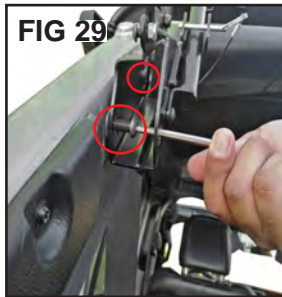

Make sure the pin secure the rear leg as shown in fig 30 & 31.

Repeat this procedure on the passenger side.



Step 11: Installing the rear bow with leg to the main bracket



In the Driver's side rear main bracket, there is a screw and nut installed for shipping (fig 32). Remove this screw and nut, and set aside. Place the Driver rear leg to the main rear bracket (fig 33 & 34).

Make sure the holes of the rear leg and main bracket line up (fig 34). Insert the screw and nut previously removed using a 10mm socket and the included 4mm Allen head tool. Tighten and secure the bracket (fig 35).

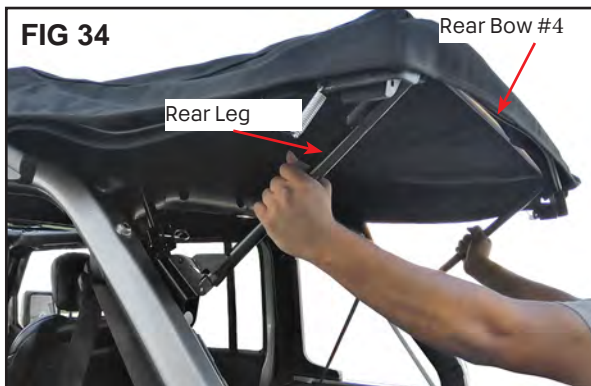

Repeat this procedure on the other side of the vehicle



Step 12: Installing the Top Deck



Once the rear bow is installed (Step 11), SLOWLY fold the front header down resting the windshield header on the windshield (fig 38). The first time you fold this header down it will be very tight. Make sure before you fold down the header that the front two header corner pockets are in place and not lifted up over the header.

Repeat on the passenger side

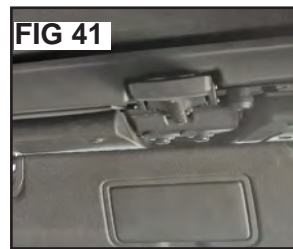
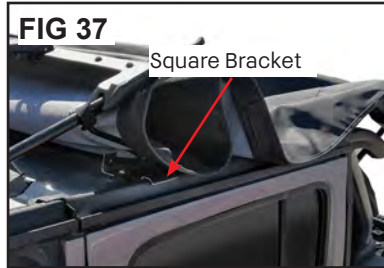

Locate the driver side square bracket on the rear driver door surround as shown in fig 37. Secure the deck to the bracket by rolling the plastic into the slot on the bracket (Fig 39). With the header resting on the windshield, close the front header latches to secure the front of the top to the windshield. See FIG's 40 & 41.

Step 13: Installing the Side Quarter window



Locate the drivers rear quarter window. Line up the driver's side Quarter window to the zipper on the deck and zip it as shown in FIG's 42 & 43

Repeat on the passenger side

Step 14: Attaching the Corner Mounts and Tailgate Bar

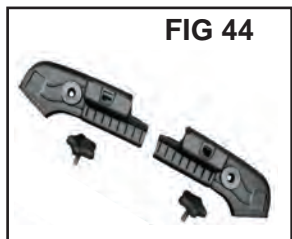

Locate the corner mounts and two short knobs (FIG 44). Locate the driver's side corner mount and line up with the corner of the body tub. With the short knob, secure the corner mount to the body tube and tighten. See Fig's 45 & 46

Repeat this procedure on the passenger side.



Step 15: Insert the Side Corner Window

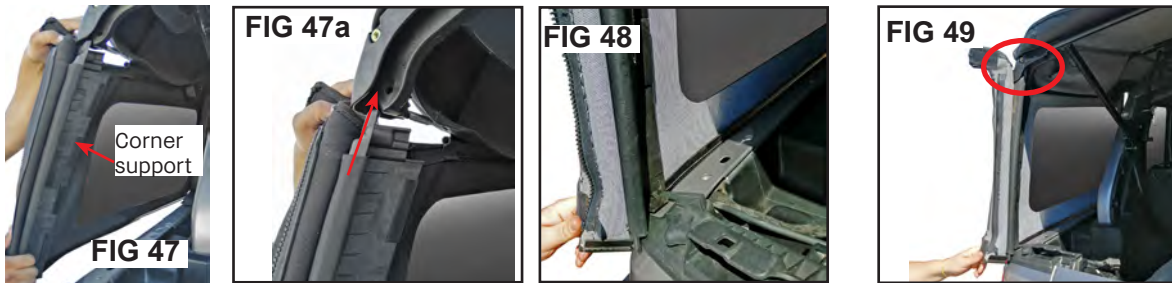

On the rear of the quarter window there is a corner support installed. The quarter window corner support will engage with the plastic piece up in the soft top (fig 47 & 47a). Once the upper is secure, in the bottom of this corner support is a tab that rests on top of the corner bracket mount installed in step 14, see Fig 48 & 49).

Repeat on the passenger side.

Step 16: Installing the Rear Windows



Locate the rear window and line up and slide the rear window into the "C" Channel located at the top of the rear portion of the top deck and slide it across (FIGs 50 & 51).

Once both quarter windows and the upper portion of the rear window are secured to the top deck, line up the driver's side rear zipper on the Quarter window to the zipper on the rear window and zip it down a few inches (FIG 52).

Repeat this on the passenger side of the rear window. You may have to lift the quarter window up to secure this second zipper a few inches. Once both side zippers are attached, zip the rear window zippers down about half way (Fig 53) making sure the top is centered over the rear bow.

You will close these zippers completely at the end of the install.



Go inside the vehicle and locate the second and third center bow hook and loop flap sewn into the top deck. Wrap this flap around the second & third center bow securing the top deck to the bows (FIG 54).



NOTICE When removing the quarter windows from the Top deck, make sure the zipper is completely out of the "zipper box" before removing the window. See fig 55a & 55b

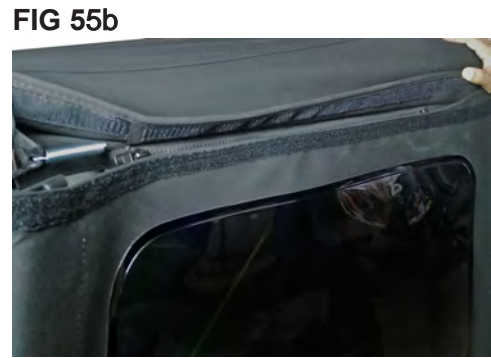

Step 17: Securing the Side and Rear Windows to the Vehicle



As shown in fig's 56 & 57, roll the vertical plastic strip into the door surround slot securing it to the door surround. Next, starting at the driver's side front, attach the side belt rail into the vehicle body by "rolling" the plastic into the slot (FIG's 58 & 59).



Note: You may have to pull the corners around towards the front or back of the vehicle to center the top on the vehicle. If this is too difficult, release the front windshield header latches. Once installed the first time these windows will easily install. Repeat this on the passenger side centering the top over the rear bow.

Seal hook and loop around windows (Fig 60 & 61)

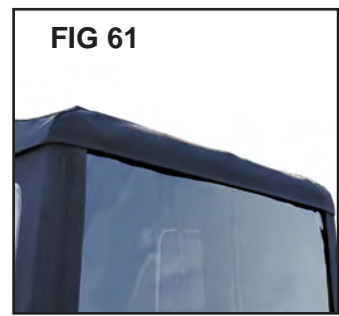

Step 18: Securing the tailgate bar & rear window to the vehicle



Take the tailgate bar and orient the “C”-Channel with the round seal facing down and slide the “C” Channel onto the rear window retainer as shown in FIG 62 & 63. After sliding the retainer all the way through the “C” Channel, roll the tailgate bar into the mounts with the outside of the fabric facing towards the rear of the Vehicle (Fig 64).

Once the Tailgate bar is secure, lower zippers on both sides of the rear curtain and move to the rear driver’s side corner mounts and “roll” the plastic into the corner mount as shown in FIG 65. Secure the rear zipper cover flap as shown in Figs 66 & 67. Repeat this procedure on the passenger side.

Using Your Complete Soft Top

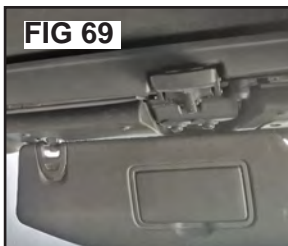

Your Soft top hardware has multiple front fold back options. Depending on how much sun and weather you want to let into the cab determines the options available to you



Option #1 & #2

Open over the front driver and passenger compartments:

Unlatch the two front Windshield latches (Fig 68 & 69). Push the front header up and over to open the “sunroof”. When you open the front portion there will be fabric still hanging down over your head(Fig 70) This is Option #1 which provides protection from the sun while opens the “sunroof”. If you push the fabric up in the center of the folded back “sunroof” and tuck/ fold it under the header, this is option #2 which opens up the “sun roof” completely. This option is shown in Fig 70A.



Using Your Complete Soft Top Continued

FIG 71



FIG 72



FIG 73



FIG 74



Option #3 & #4

Fully Open Front and Rear Passenger "Sun Roof":

These options open both the front cab and rear cab portions of the top. This option requires you to remove the front header arms and the two bows from the bow mount brackets. Fig 71 shows the finished look of this "Sun Roof" option with the front header installed on the third bow bracket mount and the header folded all the way back to the rear of the vehicle.

With the header latches un-latched and front section open (Fig 71) un-hook the 2 quick release knobs located on the end of the header arms as circled in Fig 72. Next, un-hook the 4 quick release knobs on bow #1 and bow #2 (Fig 72) leaving the two rear bows (Bow #1 & #2) encased in the hook and loop flaps. Once the front bow arms and two rear bows are disconnected from the bow mount brackets, with the help of a friend, carefully fold back the front header and two bows layering the top and bows under the fabric and then connect the front bow arms quick release brackets to the rear-most third bow mount bracket as circled in Fig 73. This is option # 3. Notice in Fig.74 how the fabric is "layered back and the front Bow Mount Brackets are installed to the rear bow brackets. This is option #4 with the entire fabric assembly folded back and secured to the rear brackets.

WARNING

The front header arms must be secure to the third bow mount bracket and the fabric/ bows must be layered back before the vehicle is driven! Failure to secure these bow mounts will cause the top to potentially fly off the vehicle causing damage to the top, vehicle and potentially other vehicles on the road.



Using Your Soft Top Hardware Continued

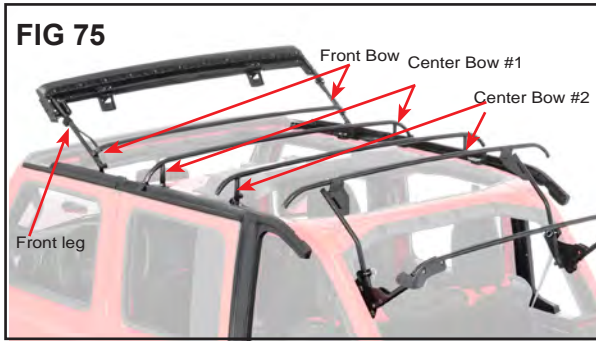

Fold Back down Feature Use and secure:

To fold back down and secure, remove the rear and quarter windows from your soft top. Unlatch the quick release knobs (both sides) from the Front, Center #1 and Center #2 bows (fig 75). Unhook the pin securing the rear leg (fig 75a). With the help of a friend, fold back the entire top to the rear of the vehicle as shown in fig 76.



Threading Straps through Buckles:

For the following strap attachment you will need to thread webbing straps through buckles. Please review the picture to the left for correct strap routing through the buckles. As a rule of thumb, run the strap below and through the sewn side of the buckle first and then back down through the end of the buckle. Tighten the strap by simply pulling the exposed webbing after threading the strap through the buckle.



To secure your soft top, locate the two side tension straps (fig 77). Hook the end of strap under the belt rail (fig 78), insert the other side of the tension strap through the strap in the front leg, see fig 79. Thread through the buckle and tight to secure as show in fig 80 & 81. Repeat on the other side of the vehicle.

WARNING When folding back your soft top, it must always be secured to the vehicle using the enclosed straps shown above. When the Top is folded back in the sun roof position, make sure the quick release knobs are secure. Failure to do so may result in damage to your vehicle, hardware system, soft top and your person.



The Perfect add-on Accessory: MasterTop 5 Layer Cab Cover for 18-Current Jeep Wrangler JLU Unlimited



Care and Maintenance of your MasterTop® Product:

Your MasterTop Fastback made of the finest materials available but to keep it looking new and for the maximum possible wear, it will need periodic cleaning and basic maintenance. The main threat to your soft top is pollutants, dirt and grime. By keeping your top clean you will prolong the life of your top. We recommend the following to keep your top like new:

Washing:

The soft top fabric should be washed often using a mild soap, warm water and a soft bristle brush. You can also use special soft top cleaners available on our Distributors websites. Make sure that after cleaning you rinse with clear water to remove all traces of soap to avoid residue.

Water/Fabric:

In the event of seeping through the seams, 3M Scotchgard® may be applied on the inside of the seams to stop the seeping. Rips in the fabric may be repaired with Bondex® iron on patches. Iron the patches to the Inside of the top, carefully following the Bondex® instructions.

Windows:

It is very important that you keep your Soft Top windows clean! Use a mild soap and water solution to gently clean your windows. NEVER wipe your windows clean with a dry cloth! Dust and dirt on a dry cloth can scratch your windows causing "fogging" and permanent damage. When removing your windows, store them with a towel. If frost or ice forms on the outside of your windows during the winter, DO NOT use an ice scraper to remove this frost. Over time you will see small micro scratches in your windows which are natural wear and tear. These Micro scratches can be "polished" out using the window polish available at your MasterTop Distributor.

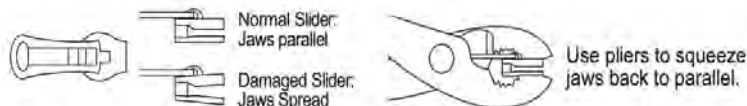

Zippers:

Keeping the zipper cleaned and lubricated with a silicone lubricant (available online) will help prevent damage and keep the zippers in a smooth working condition. If zipper opens behind the slider, the slider may have been spread apart. This problem can usually be fixed by using an ordinary pair of pliers to bring the sides back into parallel. Return slider to the end of the zipper in the normal Open position. Squeeze lightly at first and test zipper. If the zipper continues to remain open squeeze more firmly with pliers and try the zipper again. Repeat procedure until your zipper operates correctly.





Limited 3 Year Warranty

Your MasterTop® accessory is covered by the following Limited Warranty provided exclusively by MasterTop, Inc., 420 J Corporate Circle, Golden, CO 80401.

This Limited Warranty is the only warranty made in connection with your purchase. MasterTop neither assumes nor authorizes any vendor, retailer or other person or entity to assume for it any other obligation or liability in connection with this product or Limited Warranty. This Limited Warranty does not apply and is not cumulative to any accessory or part distributed by any MasterTop distributor for which the Manufacturer provides a separate written warranty.

What is Covered: Subject to the terms, exclusions and limitations herein and with respect only to MasterTop branded accessories first sold in the United States, MasterTop warrants to the initial retail purchaser only that your MasterTop accessory shall be free of defects in material and workmanship; **for a period of 3 years from date of initial retail sale.**

All other warranties are hereby disclaimed, except to the extent prohibited by applicable law in which case any implied warranty of merchantability or fitness for a particular purpose on this product is **limited to 3 years from date of initial retail sale.** MasterTop reserves the rights to: (a.) require invoice or other proof your product is within the terms of this Limited Warranty as a condition of warranty service and, (b.) make future revisions to this product and Limited Warranty without prior notice or obligation to upgrade your product.

What is Not Covered: Your MasterTop Limited Warranty does not cover products or parts MasterTop determines to have been damaged by or subjected to: (a.) installation damage, alteration, modification, failure to maintain or attempted repair or service by anyone not authorized by MasterTop, (b.) normal wear and tear, cosmetic damage or damage from water immersion, (c.) Acts of God, accidents, misuse, negligence, inadequate mounting or impact with vehicle(s), obstacles or other aspects of the environment, (d.) theft, vandalism or other intentional damage, (e.) fleet, rental or commercial use, (f.) use in competition or racing.

Remedy Limited to Repair/Replacement: The exclusive remedy provided hereunder shall, upon MasterTop inspection and at MasterTop's option, be either repair or replacement of product or parts (new or refurbished) covered under this Limited Warranty. Customers requesting warranty consideration on MasterTop Products should first contact MasterTop to obtain a RGA number (720-575-5440). All labor, removal, shipping and installation costs are customer's responsibility.

Other Limitations - Exclusion of Damages

- Your Rights Under State Law:

In consideration of the purchase price paid, neither MasterTop nor any independent MasterTop distributor /licensee are responsible for any time loss, rental costs, or for any incidental, consequential, punitive or other damages you may have or incur in connection with any part or product purchased. Your exclusive remedy hereunder for covered parts is repair/replacement as described above.

This Limited Warranty gives you specific rights. You may also have other rights that vary from state to state. For example, some states do not allow limitations of how long an implied warranty lasts and/or do not allow the exclusion or limitation of incidental or consequential damages, so the limitations and exclusions herein may not apply to you.

© MasterTop, Inc. 2022. All Rights Reserved. The terms MasterTop® and MasterTwill® are Registered Trademarks of MasterTop Incorporated, Registered in U.S. Patent and Trademark Office.

www.MasterTop.com

Part # 941082.01 Version 11.8.22 LTR

